

**41000**

# Butterfly valve of stainless steel DN 80 - 350

18.05.2007

## Operation

Butterfly valve 41000 is an on-off and control valve for demanding industrial pipelines. The valve is tight to both directions of flow.

**Nominal pressure** PN 25  
**Closing pressure difference** CS 20 bar  
 TS 25 bar

**Disc seal alternatives** Metal, PTFE

### Temperature and tightness class

**Metal** max +260°C/ min -40°C  
 ISO 5208, EN 12266-1 RATE B  
**PTFE+C** max +180°C/ min -40°C  
 ISO 5208, EN 12266-1 RATE A

The max pressure difference depends on the working temperature

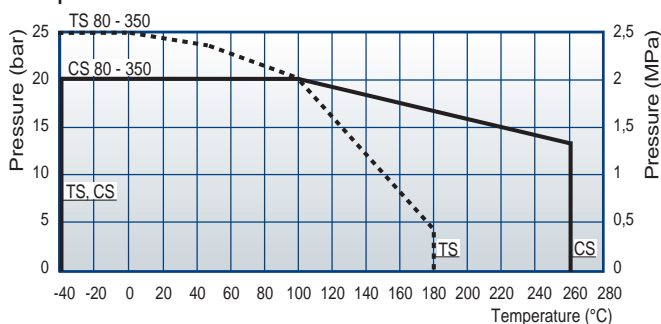

## Construction

The body of this wafer type butterfly valve is made of stainless steel. The double eccentric disc and stem are of stainless steel as well. Stem seals are tightable graphite seals and O-rings.

Conform with the requirements of the Council Directive 97/23/EC on Pressure Equipment, marking:

Class: Gas, group 1



**Face-to-face length** according to ISO 5752 SFS 4132 series 25 DIN 3202 K2

**Nominal dimensions:** DN80 - 350

### Product codes:

41000CS\_ \_ \_ \_ metal seated  
 41002TS\_ \_ \_ \_ teflon seated  
 41000 \_ \_ \_ \_ with handlever  
 41000 \_ \_ \_ Z with bare shaft  
 41000 \_ \_ \_ M with manual gear

**Connection** between flanges SFS 2123 = DIN 2501 PN 25, PN 16, PN 10, ANSI CLASS 150

For steam on special order: Product code **41001CS**  
 FIRE SAFE accepted

## Materials

**Body:** Stainless steel ASTM A351 CF8M  
**Flange:** Stainless steel ASTM A351 CF8M, EN 10028-7 1.4436  
**Disc:** Stainless steel EN 10213-4 1.4408, ASTM A351 CF8M  
**Shaft:** Stainless steel EN 10088-3 1.4460  
**Disc seal:** Stainless steel or PTFE+C  
**Shaft seal:** Graphite/ EPDM or Graphite/ FPM

41000

# Butterfly valve of stainless steel DN 80 - 350

18.05.2007

## Dimensions

DN	D1	D	L	h1	d1	h	H	Flange ISO5211	Weight kg
80	138	72	49	45	15	114	144	F07	6,5
100	158	89	56	52	20	131	168	F07	8,4
125	188	113	64	52	20	143	179	F07	10,5
150	212	137	70	58	25	160	199	F10	15
200	268	187	71	58	25	200	224	F12	31 *)
250	320	238	76	63	30	232	269	F12	40 *)
300	370	286	83	69	35	275	308	F14	57 *)
350	430	337	92	69	35	303	335	F14	71 *)

\*) with manual gear

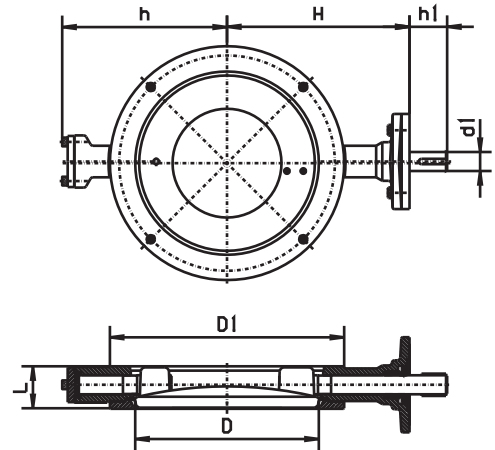

## Operation

The butterfly valve is delivered with handlever, manual gear, electric, pneumatic or hydraulic actuator according to customer's needs.

## Handlever

The smaller sizes, DN 80 -150 can be operated with handlever. The opening and closing of valves is stepless.

The valve is open when the handlever is parallel to the pipe.

DN	h	H	A
80	114	223	300
100	131	246	300
125	143	260	300
150	160	289	420

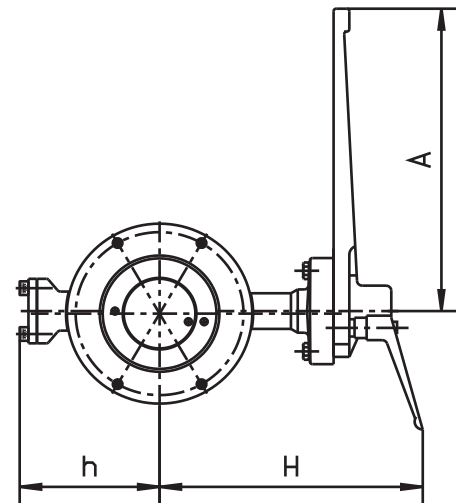

## Manual gear

Opening and closing of the valves from the handwheel. The position of disc can be seen on a position indicator on top of the gear.

DN	D	h	H	a	b	c	d
80	138	114	219	220	53	178	200
100	158	131	243	220	53	202	200
125	188	143	254	220	53	213	200
150	212	160	290	270	71	242	200
200	268	200	315	270	71	267	200
250	320	232	360	322	71	312	300
300	370	275	408	330	97	358	400
350	430	303	435	330	97	385	400

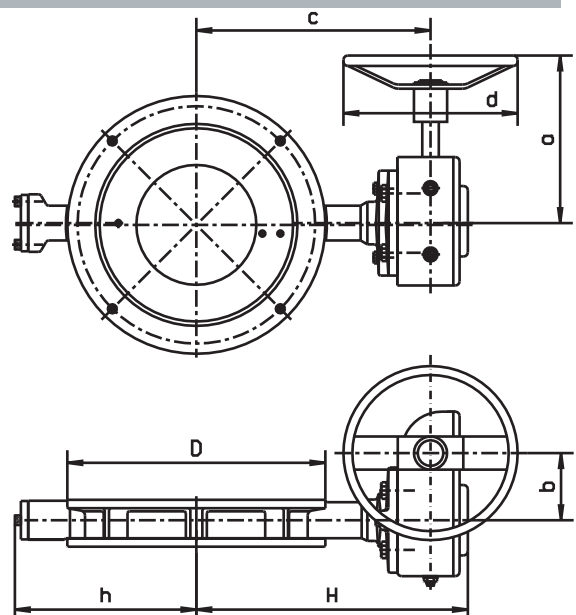

The control curves

The curves indicate the regulating values of the valve at different opening angles.

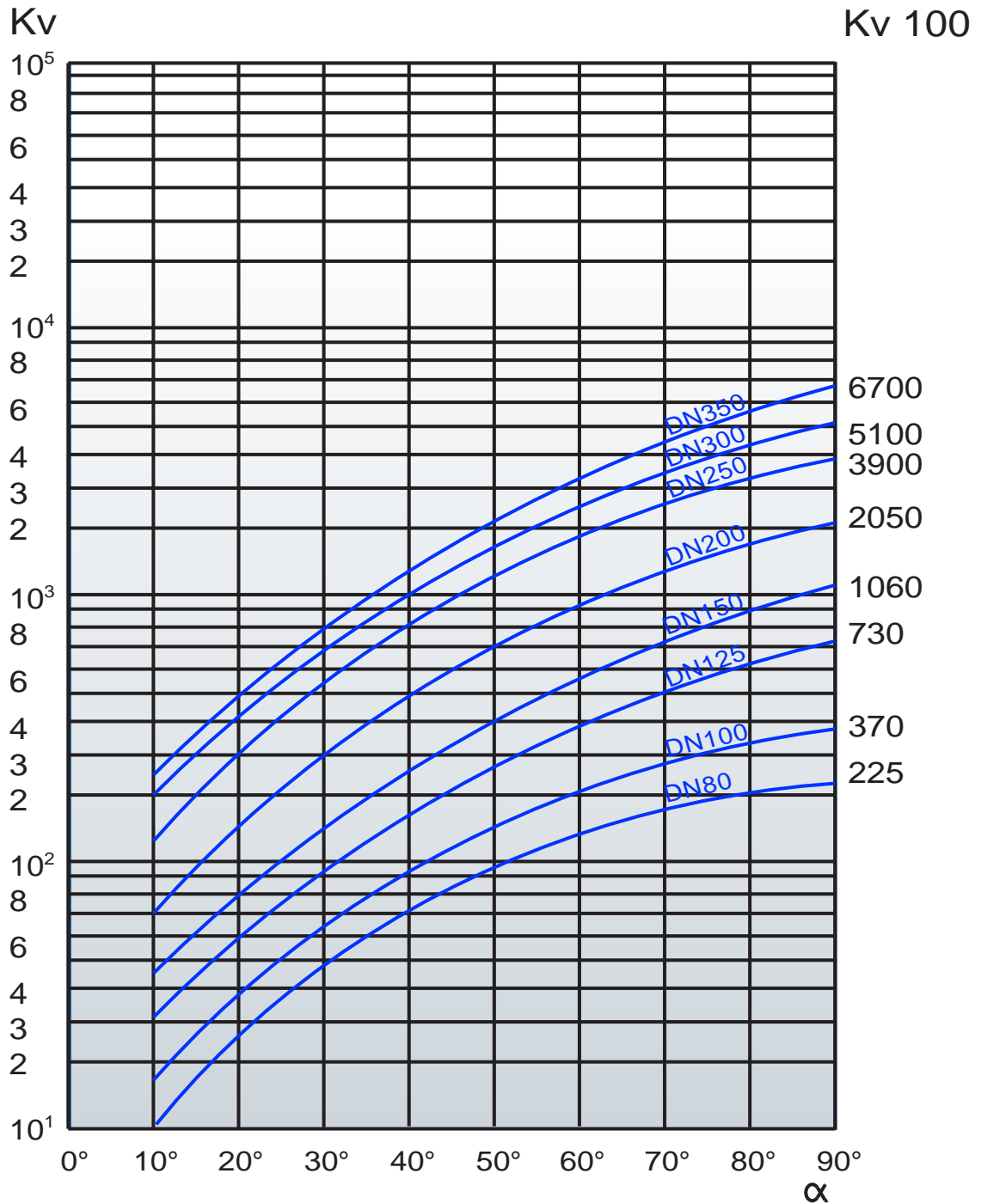

**WATER:**

**Volume flow:**

$$Q = K_V \sqrt{\frac{\Delta p}{\rho}}$$

**Flow velocity:**

$$v = 354 \frac{Q}{DN^2}$$

- $K_V$  = kv-value — Capacity factors
- $DN$  = nominal valve size (mm)
- $\alpha$  = disc opening angle
- $Q$  = volume flow m<sup>3</sup>/h
- $\Delta p$  = pressure difference bar
- $\rho$  = density of liquid kg/dm<sup>3</sup>
- $v$  = flow velocity m/s