

36000

Pipe branch control valve DN 40 - 200

06.02.2007

Operation

Högfors pipe branch control valve is an ideal multi-purpose, on-off and control valve which can be used in pipelines for balancing and stopping the heat conduction.

Nominal pressure PN 25

Tightness class ISO 5208, EN 12266-1 RATE A

Operating temperature max +150°C/ min -20°C

The max pressure difference depends on the working temperature

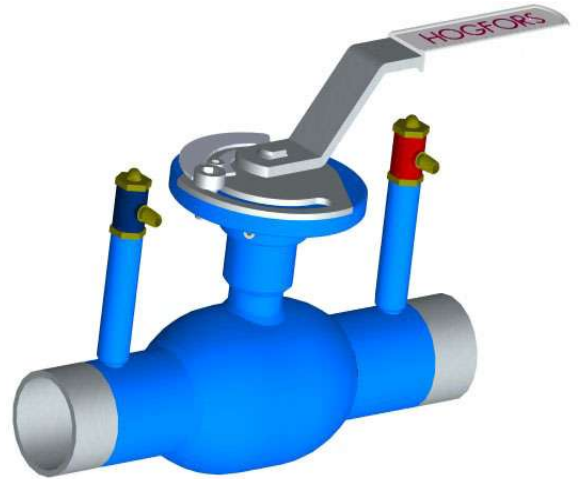
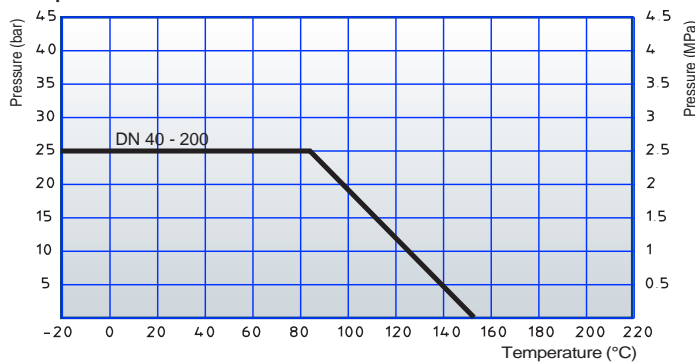

Construction

Högfors welded pipe branch control valve 36000 has a body made of carbon steel. Floating ball and blow-out proof stem are made of stainless steel. Ball sealing is of PTFE+C. Stem has O-rings. The valve adjustment functions excellency is due to the v-port in the valve seat. The pipe ends are equipped with needle-throttle valve connections. During a through-flow of water the pressure loss occurring in the pipe branch control valve is indicated by the attached differential pressure gauge, i.e. it shows the pressure difference between the measuring points. The amount of water flowing through the control valve into the heating device can be adjusted by means of the measured differential pressure value and the diagram of the pipe branch control valve. The valve has stepless adjustment. The scale dial ranges from 0 to 9.

Conform with the requirements of the Council Directive 97/23/EC on Pressure Equipment, marking:

Class: Gas, group 2



Nominal dimensions: DN 40 - 200

Product codes: 36000TR_ _ _ with handlever
36000TR_ _ _ Z with bare shaft
36000TR_ _ _ M with manual gear

Dimensions

DN	d	D	s	L	H	k	Weight kg
40	31	48,3	2,9	260	111	10	3,0
50	39	60,3	2,9	300	123	10	3,5
65	50	76,1	2,9	300	136	12	5,7
80	65	88,9	3,2	300	147	12	7,2
100	80	114,3	3,6	325	191	17	11,3
125	100	139,7	4,0	325	206	17	16,6
150	125	168,3	4,5	350	269	19	28,8
200	150	219,1	6,3	400	394	ø30	54 *)

*) with manual gear

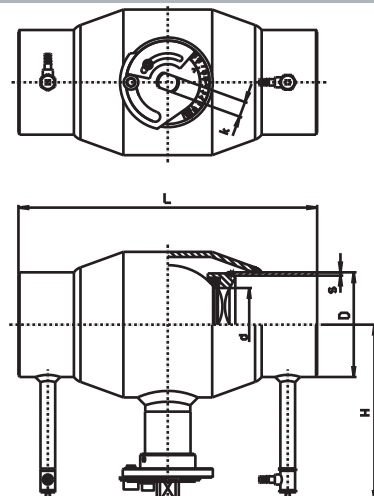

The control curves

